

one2clean / one2clean plus Multi-Tank System Installation instructions

one2clean

Item no.

106854 Installation kit 7 PE
106855 Installation kit 10 PE
106856 Installation kit 14 PE
106857 Installation kit 18 PE

one2clean plus

Item no.

106425 / 106421 Installation kit 7 PE
106426 / 106422 Installation kit 10 PE
106427 / 106423 Installation kit 14 PE
106428 / 106424 Installation kit 18 PE



The points described in these instructions must be observed in all cases. Failure to do so shall invalidate the warranty. For any additional items purchased through GRAF, you will receive separate installation instructions in the transport packaging.

The components must be checked for any damage before the system is transferred to the pit.

You will receive separate instructions for operation and maintenance of the system.

Contents

1. SCOPE OF SUPPLY	14
2. PLEASE NOTE:	15
2.1 Safety	15
2.2 Ventilation	15
3. INSTALLATION AND OPERATING PRINCIPLE	16
4. FITTING THE INSTALLATION KIT	17
4.1 Drilling the tank shells	17
4.2 Assembly of first tank	17
4.3 Assembly of second tank	19
5. INSTALLING THE CONTROL UNIT INDOORS	22
6. INSTALLING THE CONTROL UNIT IN AN EXTERNAL CONTROL CABINET	23
7. TECHNICAL DATA	24

1. Scope of supply

1. Scope of supply

		
Lifter	Sampling unit	2 pipe aerators for 7 and 10 PE, 4 pipe aerators for 14 and 18 PE
		
Pipes	Excess sludge lifter	Accessories
		
Control unit (one2clean plus control without illustration)		

The following items are not included in the shipment:

- Hoses to supply air from the switch cabinet to the septic tanks. Air hoses (2 x 13 mm, 2 x 19 mm) are needed.

The hoses can be ordered by the reel:

20-metre PVC hose, black, 13 x 3 mm	934017
20-metre PVC hose, blue, 19 x 3 mm	934020
20-metre PVC hose, transparent, 13 x 3 mm	934011

- Core drill Ø 124 mm. This can be purchased from Otto Graf GmbH using article number 202003.
- Carat S septic tank and covers must be ordered separately.

2. Please note:

2. Please note:

2.1 Safety

All work should be undertaken in compliance with national accident prevention regulations. A second person is required for safety reasons, particularly when inspecting tanks.

In addition, the applicable national regulations and standards must be respected during installation, assembly, maintenance, repairs etc.

The entire system must always be switched off and secured against unauthorised resetting during any work on the system or system components.

The tank cover must always be kept closed, except during work inside the tank, otherwise the risk of accidents is high. Only original GRAF covers, or covers approved by GRAF in writing, are to be used.

GRAF provides an extensive range of accessories, which are all coordinated and can be combined to form complete systems. The use of accessories that have not been approved by GRAF results in the exclusion of the warranty/guarantee.

2.2 Ventilation

All tanks must be ventilated. Additional ventilation ducts or openings are to be arranged if required. If this occurs, the ventilation ducts should be arranged so that natural ventilation is possible (chimney effect).

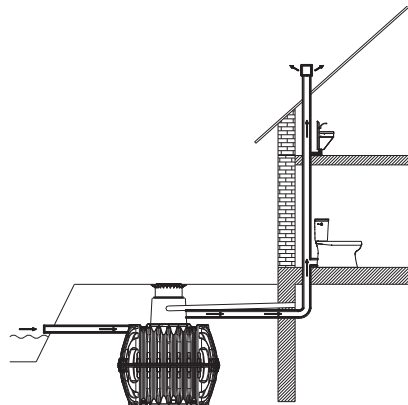

Ventilation with unobstructed outflow

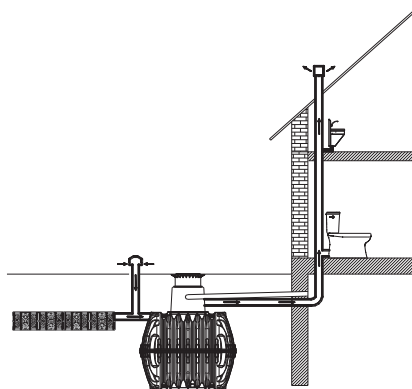

Ventilation in the case of infiltration or with obstructed outflow

3. Installation and operating principle

3. Installation and operating principle

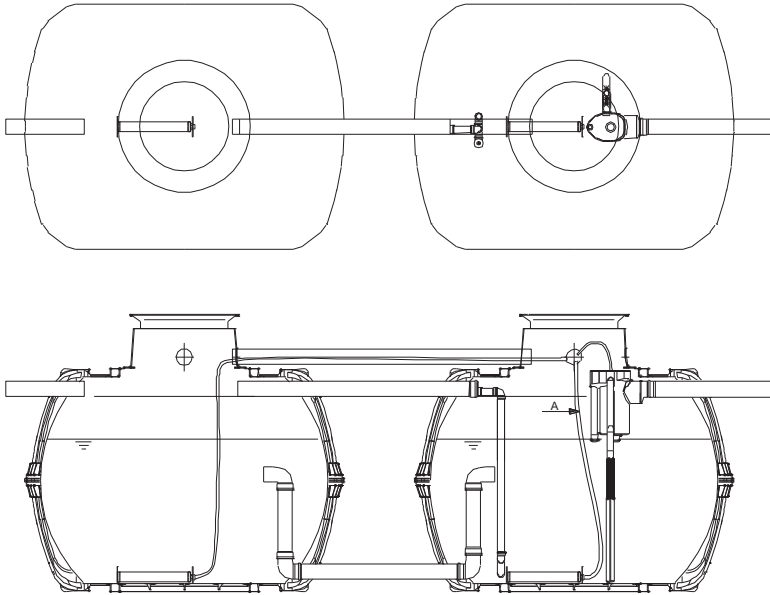

The system is a fully biological small wastewater treatment system and functions on the principle of the retention process with extended aeration. The system consists of an aerobic stage split into two tanks. The two tanks are connected in the lower area so that the water level is always the same in both tanks. This process therefore subjects all the domestic wastewater directly to aerobic wastewater treatment. Blowing in compressed air aerates the entire system and the sludge aerated by this biologically cleans the wastewater.

4. Fitting the installation kit

4. Fitting the installation kit

4.1 Drilling the tank shells

1. 

H		H	
2700 L	3750 L	4800 L	6500 L
145 mm	145 mm	190 mm	205 mm

Drill holes for the inlet, outlet and connecting lines on the shells using a DN 110 core drill (diameter 124 mm).

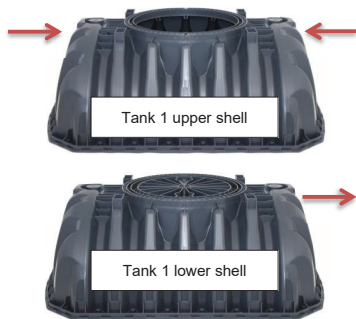
2. 

On the first tank, the holes for the inlet and outlet lines are drilled as shown above. The arrows indicate the direction in which the pipe is fed through.

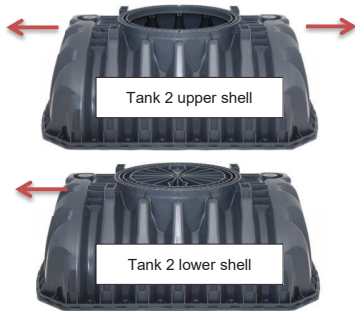
3. 

On the second tank, the holes for the inlet and outlet lines are drilled as shown above. The arrows indicate the direction in which the pipe is fed through.

4. 

Deburr hole. Insert DN 110 edge seal. The feed-through direction can be seen in the previous diagram.

4.2 Assembly of first tank

5. 

2700 L	H= 400 mm
3750 L	H= 500 mm
4800 L	H= 750 mm
6500 L	H= 900 mm

Assemble the lower overflow baffle between the tanks. The socket connections must be secured using Spax screws.

6. 

Insert overflow baffle in lower shell.

4. Fitting the installation kit

7.



Assemble the Carat S tank as described in the installation instructions (seal, centring pins, clips, position upper shell)

8.



Fit the tank dome as described in the installation instructions (seal!).

9.



A cord must be attached to the pipe aerator (6mm hole). The air hose (19mm) is connected on the opposite side.

10.

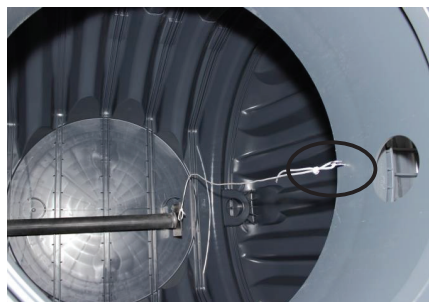

To attach the cord, a hook is fitted inside the tank dome. The hole for the hook should be pre-drilled with a 4mm bit.

11.

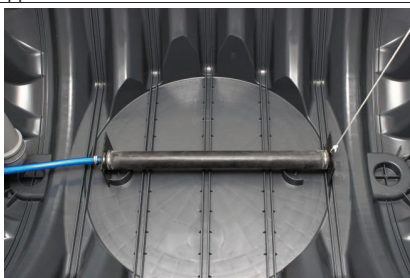

The pipe aerator(s) are positioned on the tank base. To attach the cord, the hook is fastened to the telescopic dome shaft.



In systems with four pipe aerators, the hoses are joined in pairs with a Y-piece.

4. Fitting the installation kit

4.3 Assembly of second tank

13.



Install overflow baffle as in first tank.

14.

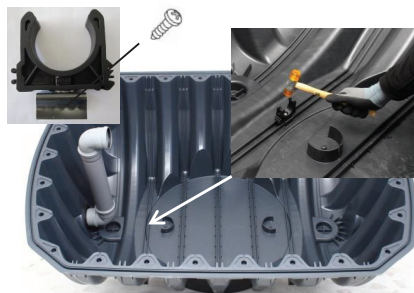

Fit the retaining clips centrally on the last base rib.

15.



Assemble the Carat S tank as described in the installation instructions (seal, centring pins, clips, position upper shell).

16.

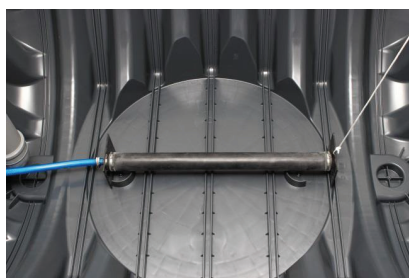

Fit pipe aerator(s) as for the first tank. To attach the cord, the hook is fastened to the telescopic dome shaft.

17.



Slide sludge return pipe from inside through the hole for the sludge return.

18.



Insert sludge return into tank.

4. Fitting the installation kit

19.

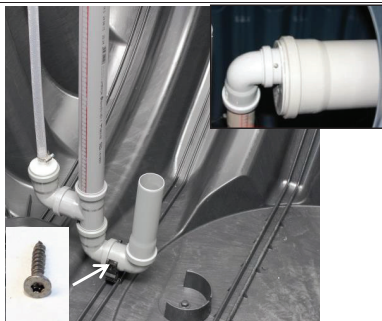

Push sludge return into retaining clip and additionally secure with Spax screw. At the top of the tank, push the sludge return into the sludge return pipe.

20.



Slide drain pipe through outlet hole from inside.

21.



Depending on tank size, the lifter shoe has to be turned. The tank size stated on the foot section must match that on the lifter.

22.

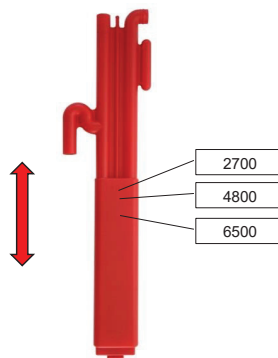

Depending on tank size, the lifter length must be adapted by moving the lifter shoe. The approximate position is stated on the lifter. The exact height should be determined in the tank.

23.



Assemble lifter and sampling unit by pressing lifter's outlet into sampling unit's hole.

24.



Press lifter into sampling unit (until it engages)

4. Fitting the installation kit

25.



Insert lifter with sampling unit in tank.



26.

The lifter is placed from above to hold the dividing wall.

27.



The sampling unit's outlet connector is placed into the outlet pipe's socket (use lubricant!). The socket connection should be secured with a Spax screw.



28.

The tank dome is fitted as described in the installation instructions (seal!).

29.



Secure sampling tank to tank dome with Spax screw.



Connect air hose (13mm) to lifter for clear water extraction. Connect air hose (13mm) to lifter for sludge return.

30.

5. Installing the control one2clean unit indoors

5. Installing the control one2clean unit indoors

1.



The control unit should be installed in a dry, dust-free indoor location. To install, drill two 8mm holes in the wall.

2.



The control unit is secured to the wall with the dowels and screws supplied.

3.



The compressor is placed on top of the control unit. Use the rubber bracket for the air connection. The compressor's connector is plugged into the socket on the control unit.

4.



The hose for clear water extraction (1/2") is directly connected to the black hose connector on the control unit. The additional air distributor is connected to the control unit's blue hose connector (3/4").

5.



The aeration hoses are connected to the two 3/4" hose connectors. The sludge return hose is connected to the 1/2" connection.



For information about starting up the wastewater treatment system and setting the control unit, refer to the operating logbook.

Note one2clean plus control unit: The assembly of the one2clean plus control unit is to be carried out in the same way as the one2clean control unit. The one2clean plus control unit is equipped with a third valve for the excess sludge removal. Therefore the air distributor with the valves is not needed.

6. Installing the control unit in an external control cabinet

6. Installing the control unit in an external control cabinet

1.



Install the external control cabinet as described in the installation instructions and establish the electrical connection.

2.



Before installing the control unit, a strip of foam rubber must be glued to the back of the control unit.

3.



The control unit is secured with the screws and wing nuts supplied with the cabinet.

4.



The compressor is placed on top of the control unit. Use the rubber bracket for the air connection. For the power connection, the compressor's connector is plugged into the socket on the control unit.

5.



The additional air distributor is fitted as described in 5.4 and 5.5.

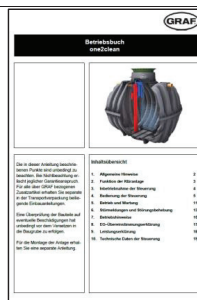

For information about starting up the wastewater treatment system and setting the control unit, refer to the operating logbook.

7. Technical data

7. Technical data

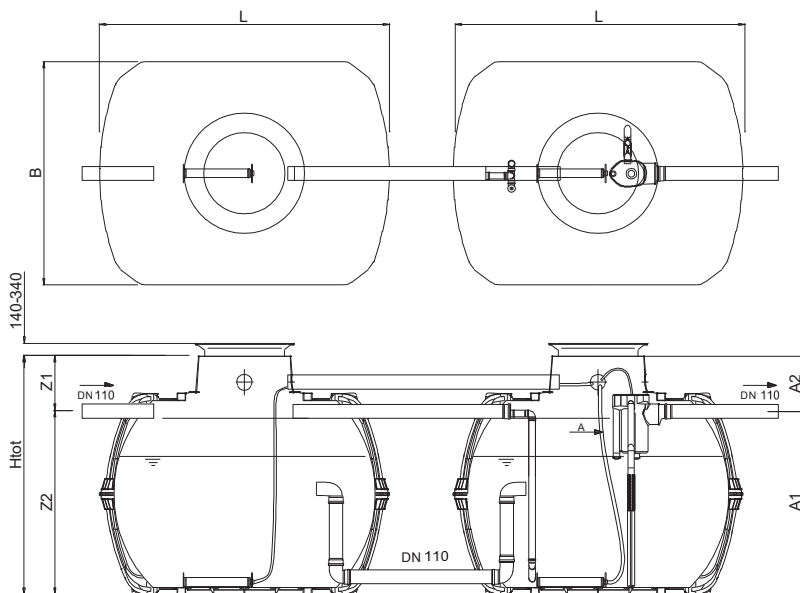

Tanks	2 x 2,700 L	2 x 3,750 L	2 x 4,800 L	2 x 6,500 L
Inhabitants	2-7 PE	8-10 PE	11-14 PE	15-18 PE
Max. daily inflow	1.05 m ³ /d	1.50 m ³ /d	2.10 m ³ /d	2.7 m ³ /d
Length L	2080 mm	2280 mm	2280 mm	2390 mm
Width B	1565 mm	1755 mm	1985 mm	2190 mm
Height H _{tot}	1690 / 2010* mm	1870 / 2200* mm	2100 / 2430* mm	2380 / 2710* mm
Inlet Z1	430 / 750* mm	430 / 750* mm	515 / 835* mm	535 / 855* mm
Inlet Z2	1260 mm	1450 mm	1595 mm	1855 mm
Outlet A1	470 / 800* mm	470 / 800* mm	470 / 800* mm	470 / 800* mm
Outlet A2	1255 mm	1445 mm	1590 mm	1850 mm

* with maxi tank dome