

# Falcon

solar light 202



**ZERO** Fuel  
Noise  
Emissions  
Maintenance



## Enhanced Design Features

### Power

The Falcon Solar Light 202 harnesses the sun's power through 3 extendable high grade solar panels that ensure maximum lighting performance and brightness.

### Security

The Falcon Solar lighting tower comes complete with galvanized retractable stabilizers for added security when in operation.

### Design Quality

The Falcon Solar Light 202 has been manufactured with high grade steel and is powder coat painted to the highest standards and c/w certified high quality electrical components.

### Easy Set Up

The Falcon Solar lighting tower comes complete with a manual winch operated mast allowing easy setup time.

## Our Mission

**We design products that harvest clean energy, minimising the impact on the environment.**

In line with the UK & European government commitments of realizing zero net carbon by 2050, we are focused on reducing carbon emissions throughout our business and supply chains by bringing the most innovative and advanced products to market in line with progress to a circular economy.



Harvesting Clean Energy / Protecting Our Environment



## Features

The Falcon Solar Light 202 is a compact and powerful Transportable solar lighting tower. The FSL-202 features 4 LED lamps which provides a brighter and more environmentally-friendly lighting system.

The innovative solar panel and trailer design make the FSL-202 easy to transport, set up & maneuver in limited spaces.



## Superior Features

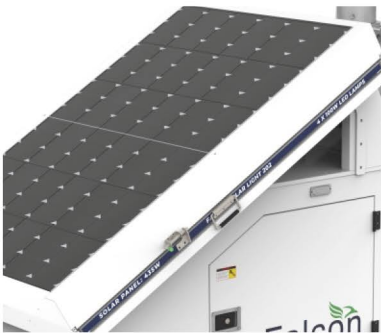

Manually extendable & adjustable Solar PV panels designed to maximise the sun's rays during daylight hours.



4 x 100W tiltable LED lighting system with 8.5m manually extendable mast with 360° rotation head providing maximum lighting coverage.



Intelligently designed electrical control panel display providing multiple user optimisation options.

## SECTORS



CONSTRUCTION



SPECIAL EVENTS



OIL, GAS &  
MINING



HARD TO REACH  
AREAS



MILITARY

# Falcon

solar light 202

## Model - FSL-202



### Specification

Brand	Falcon
Name	Solar Light Tower
Model	FSL-202
Material	Steel Q235
Powder	Outdoor Type
Transport Dimension (LxWxH)	2200 x 1600 x 2200 (mm)
Operate Dimension (LxWxH)	3200 x 3400 x 9000 (mm)
Weight	1300kg
System Voltage	DC48V

### Solar System

Solar Panel	3 x 435W Monocrystalline Silicon 108pcs
Voltage	DC39V
Charging Time	6.6 hours

## Light System

LED flood light	4 x 100W outdoor waterproof 60000lm
Protection Class	IP65
Efficiency	150Lm/W
Voltage	DC48V
Running Time	20.5 hours

## Mast System

Body	Steel Q235 Galvanized
Fastener	Stainless steel 304
Wire Rope	Stainless steel 316 8mm
Type	Square Telescopic
Height	8.5m
Section	5
Rotation	360° automatic (optional)
Tilt	90° automatic (optional)
Spring Cable	Power Supply
Lifting Method	Electric lifting
Recommended Loading	5kg ~ 70kg
Windproof	117kph

## Charger System

Rated Power	2.5kW / 2.5kVA
Frequency	50Hz / 60Hz
Plug & Socket	1 x AC 110V/220V Input



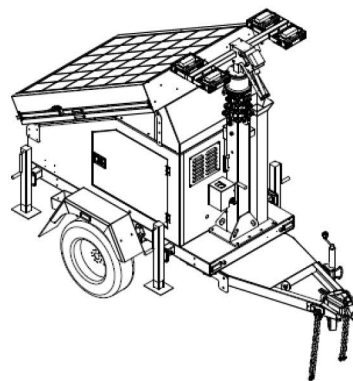
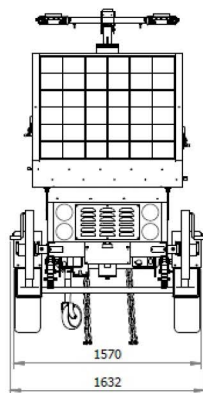
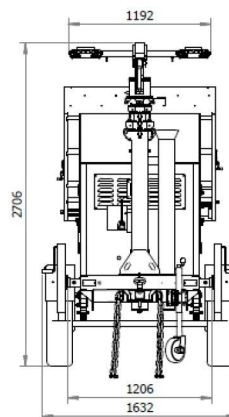
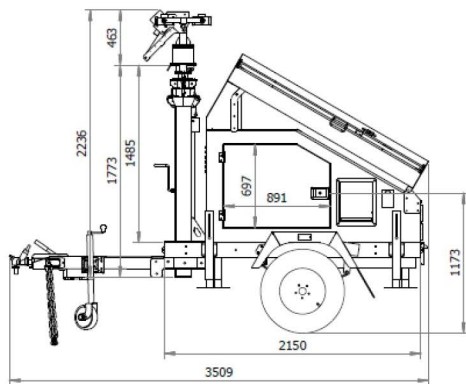

## Transport Dimensions

Length (L) (mm)	2200	Weight (Kg)	1300kg
Width (W) (mm)	1600	Loading capacity in 40 HQ (units)	07
Height (H) (mm)	2200		



2400 SQM



0% EMISSIONS



0% NOISE



0% FUEL



RUN TIME  
365 NIGHTS



07 PER TRUCK

Harvesting Clean Energy / Protecting Our Environment

## Battery System

Lithium-ion battery (LFP) 2 x 200Ah BMS

Voltage DC25.6V

Power Capacity 10240Wh

## Control System

Solar Controller Victron MPPT 35A

Efficiency 95%+

Detection & Protection Short-Circuit, Overload, High Voltage, High Temperature

Timer Manual

Whole Machine Battery Isolator, Light on-off

## Trailer System

Standard US / AU / EU

Tow Hitch 50mm / 2" Ball Type

Trailer Light 7 Pin

Jockey Wheel 200mm / 8"

Axle Single Suspension Bump Brake

Tire 2 x 15 inch

Wheel Chock 2

Forklift Hole 2

Outrigger 4 x Manual Galvanized

Warranty 3 years