

Falcon

solar light 204



ZERO Fuel
Noise
Emissions
Maintenance



Enhanced Design Features

Power

The Falcon Solar Light 204 harnesses the sun's power through 3 extendable high grade solar panels that ensure maximum lighting performance and brightness.

Security

The Falcon Solar lighting tower comes complete with galvanized retractable stabilizers for added security when in operation.

Design Quality

The Falcon Solar Light 204 has been manufactured with high grade steel and is powder coat painted to the highest standards and c/w certified high quality electrical components.

Easy Set Up

The Falcon Solar lighting tower comes complete with automatic telescopic mast operated by a push button device conveniently located on the unit.

Our Mission

We design products that harvest clean energy, minimising the impact on the environment.

In line with the UK & European government commitments of realizing zero net carbon by 2050, we are focused on reducing carbon emissions throughout our business and supply chains by bringing the most innovative and advanced products to market in line with progress to a circular economy.



Harvesting Clean Energy / Protecting Our Environment

Features

Falcon Solar Light 204 is a compact and powerful portable solar lighting tower. The FSL-204 features 4 LED lamps which provides a brighter and more environmentally-friendly lighting system.

The innovative solar panel and trailer design make the FSL-204 easy to transport and set up without taking up valuable space.



Superior Features

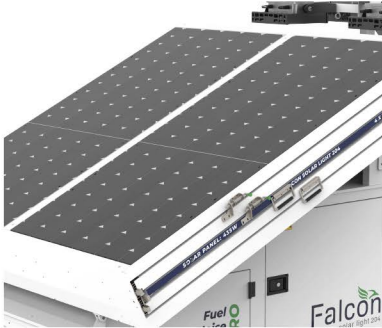

Manually extendable & adjustable Solar PV panels designed to maximise the sun's rays during daylight hours



4 x 100W tiltable LED lighting system with 9m electrically extendable mast and 360° rotation head providing 2400 sq.m of lighting coverage



Intelligently designed electrical control panel display providing multiple user optimisation options

SECTORS



CONSTRUCTION



SPECIAL EVENTS



OIL, GAS &
MINING



HARD TO REACH
AREAS



MILITARY

Falcon

solar light 204

Model - FSL-204



Base System

Brand	Falcon
Name	Solar Light Tower
Model	FSL-204
Material	Steel Q235
Powder	Outdoor Type
Transport Dimension (LxWxH)	2600 x 2300 x 2250 (mm)
Operate Dimension (LxWxH)	3700 x 6500 x 9250 (mm)
Weight	2400kg
System Voltage	DC48V

Solar System

Solar Panel	6 x 460W Monocrystalline Silicon 144pcs
Voltage	DC39V
Charging Time	6.3 hours

Light System

LED flood light	4 x 200W outdoor waterproof 120000lm
Protection Class	IP65
Efficiency	150Lm/W
Voltage	DC48V
Running Time	20.5 hours

Mast System

Body	Steel Q235 Galvanized
Fastener	Stainless steel 304
Wire Rope	Stainless steel 316 8mm
Type	Square Telescopic
Height	9m
Section	9
Rotation	360° automatic (optional)
Tilt	90° automatic (optional)
Spring Cable	Power Supply
Lifting Method	Hydraulic lifting
Recommended Loading	5kg ~ 100kg
Windproof	117kph

Charger System

Rated Power	2.5kW / 2.5kVA
Frequency	50Hz / 60Hz
Plug & Socket	1 x AC 110V/220V Input

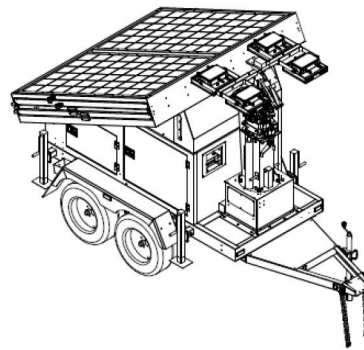
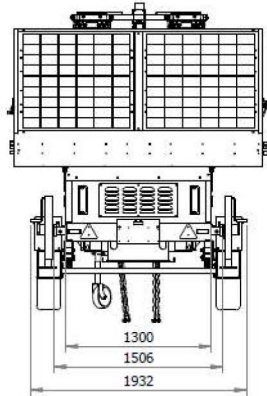
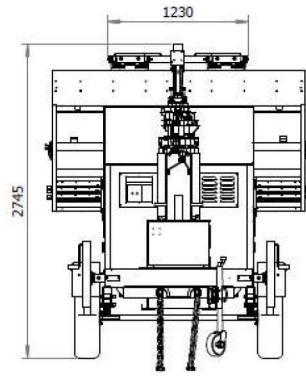
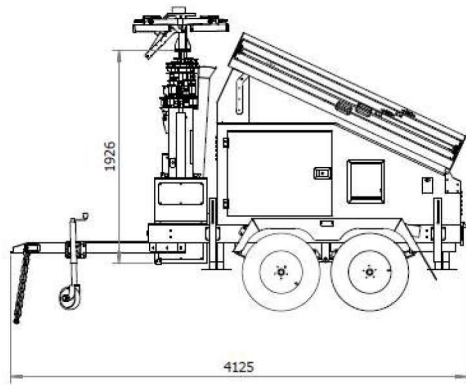

Transport Dimensions

Length (L) (mm)	2600	Weight (Kg)	2400kg
Width (W) (mm)	2300	Loading capacity in 40 HQ (units)	04
Height (H) (mm)	2250		



2400 SQM



0% EMISSIONS



0% NOISE



0% FUEL



**RUN TIME
365 NIGHTS**



04 PER TRUCK

Harvesting Clean Energy / Protecting Our Environment

Battery System

LEP 4 x 200Ah BMS

Voltage DC25.6V

Power Capacity 20480W.h

Control System

Solar Controller Victron MPPT 70A

Efficiency 95%+

Detection & Protection Short-Circuit, Overload, High Voltage, High Temperature

Timer Manual

Whole Machine Battery Isolator, Light on-off

Trailer System

Standard US / AU / EU

Tow Hitch 50mm / 2" Ball Type

Trailer Light 7 Pin

Jockey Wheel 200mm / 8"

Axle Dual Suspension Bump Brake

Tire 4 x 15 inch

Wheel Chock 2

Forklift Hole 2

Outrigger 4 x Manual Galvanized

Warranty 3 years