



KIT LUBE



DISPENSERS



PUMPS



METERS



NOZZLE METERS



NOZZLES

FILTROLL

FEATURES

- DOUBLE-STAGE FILTRATION
- CLOGGING INDICATOR
- TRANSPORTABLE
- MANAGEABLE
- SPIRAL TUBES

The Piusi FILTROLL is an innovative solution that allows the user to perform a circular filtering of any kind of tank. The built-in trolley allows the operator to easily handle this device in any condition.

PERFORMANCE

up to

56L

(up to 15 gal)

TANK CAPACITY

230V

AC VOLTAGE

POWER

DC version

30MIN

only for diesel

DUTY CYCLE



FILTROLL OIL/DIESEL



PACKAGING

CODE	WEIGHT		PACKAGING			
	KG	LBS	MM	INCH	PCS/PALLET	PCS/BOX
FO0506010	42	92,6	790X590X590	31,1X23,2X23,2		1



WASTE OIL EQUIPMENTS



FILTRATION



FLUID MONITORING



HOSE REELS



ACCESSORIES



MERCHANDISE

INDEX



AIR



ANTIFREEZE



AdBlue®



BIODIESEL



DIESEL



FOOD



GASOLINE



GREASE



KEROSENE



OIL



WATER



WINDSCREEN

CHARTS

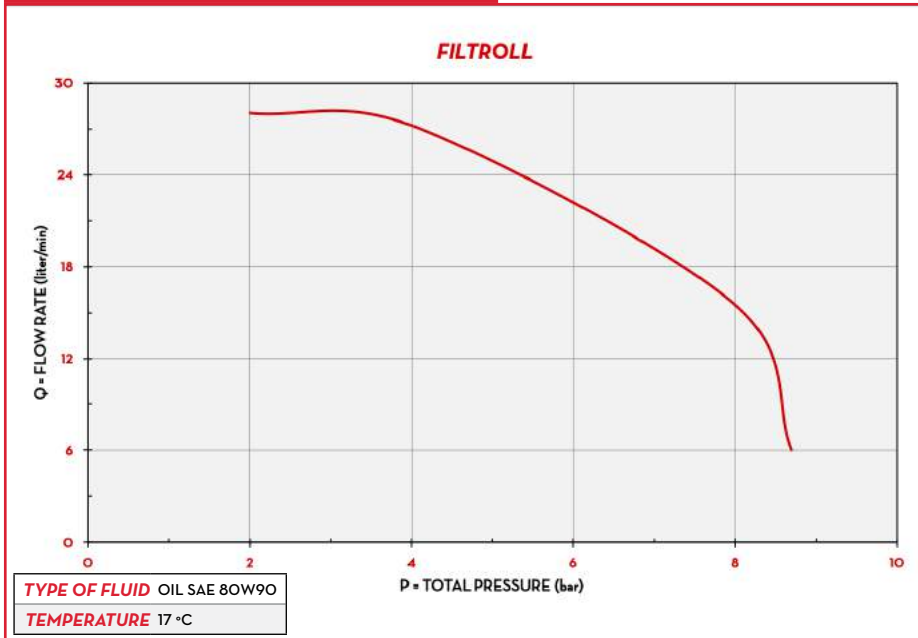

IN THE BOX

- FILTROLL UNIT
- SUCTION HOSE
- DELIVERY HOSE
- INSTRUCTION MANUAL

DETAILS



TWO STEP FILTRATION



STURDY STRUCTURE



LARGE DIAMETER WHEELS

MATERIALS

- BODY: CAST IRON
- ROTOR: SINTHERED STEEL
- VAINS: TECHNOPYLIMER
- SHAFT: STEEL
- FILTER: ABSORBENT FILTERING PAPER

DIMENSIONS

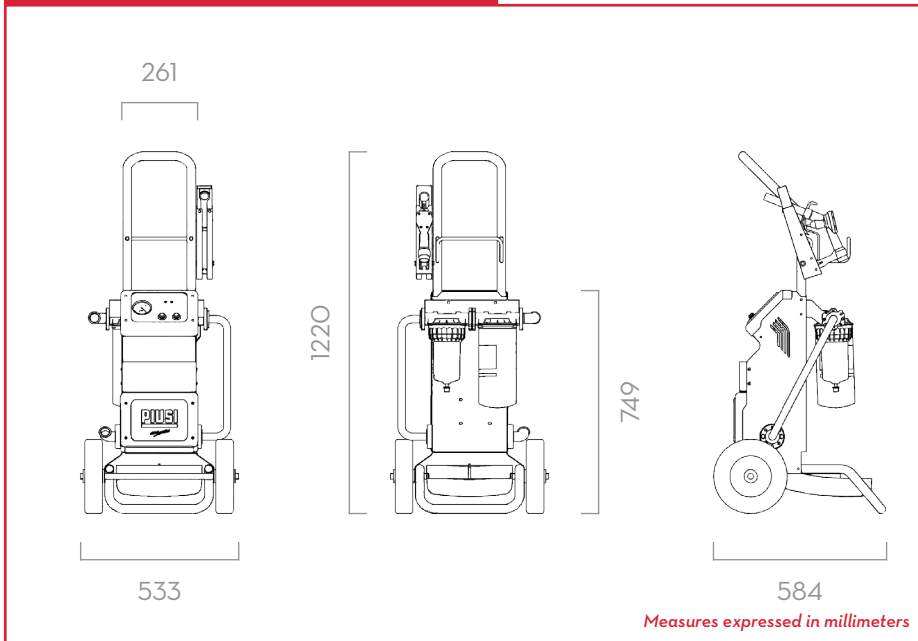

TECHNICAL DATA

CODE	DESCRIPTION	FLUIDS TYPE	FLOW RATE		VOLTAGE			PUMP	HOSE LENGHT		
			L/MIN	GPM	AC V/ HZ	DC VOLT	POWER WATT		AMP. MAX.	TYPE	DELIVERY M/FT
FO0506010	FILTROLL OIL/DIESEL	D O	25	7	230/50		750	4,6	VISCOMAT 70	3 / 9,8	3 / 9,8

FILTROLL