

Cover removed for clarity

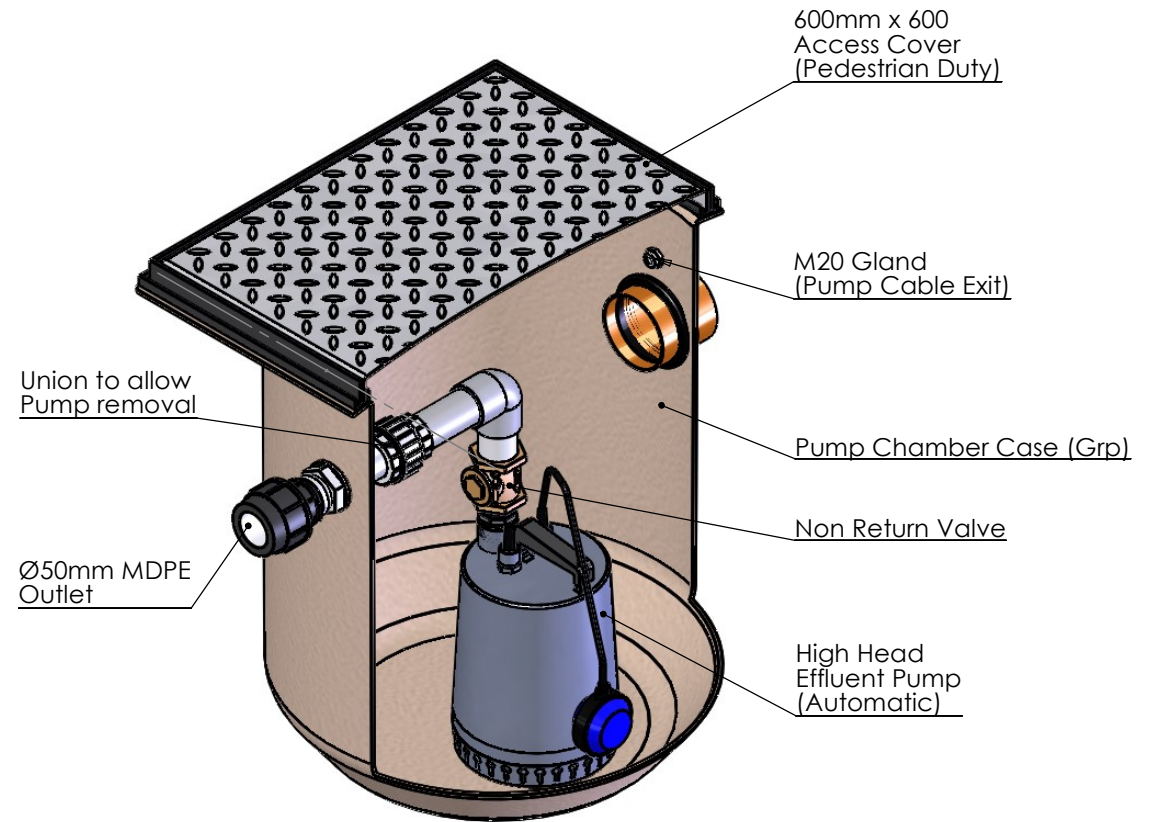
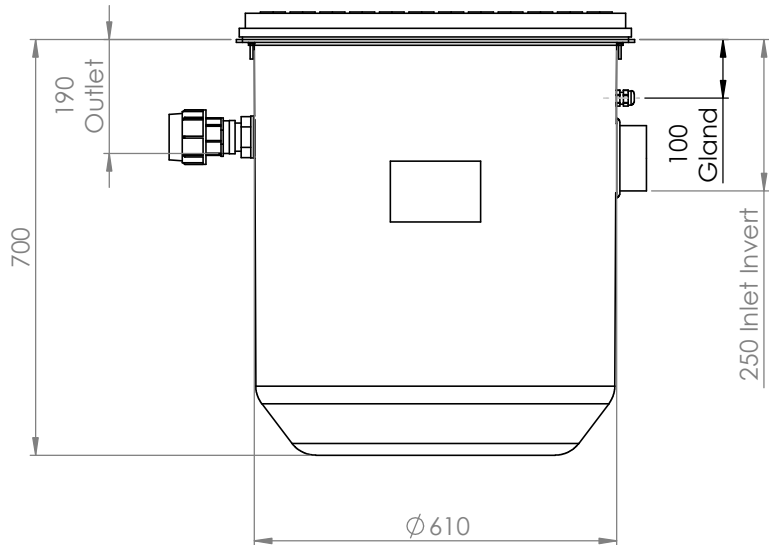
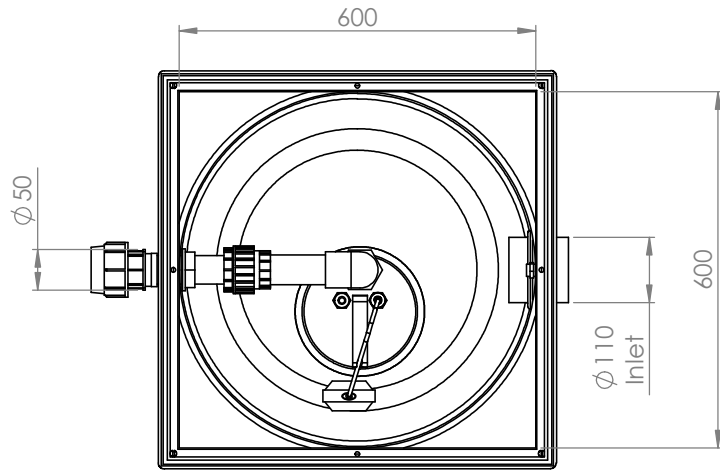

Notes:

- Pumpwell delivered with pump pre-fitted.
- Read Operating and Installation Guidelines before installing.

Please check with Kingspan Environmental that this drawing is the latest issue

Issue	Date	Drawn by	Approved by	Description	Material : Various	Tolerance :	Drawing : DS1208P
03	21/07/17	WMD		CC1382 - Pump revision	Finish :	Thickness : n/a	Page 1 of 1
02a	25/07/13	JMcM		CN235 - Inlet Invert reduced to 250mm	Weight : 30.63 Kg Kgs	Surface Area :	Mini Pump Chamber - High Head Effluent
01	06/11/12	JMcM		Initial Release			

All dimensions in mm

Scale: Not to scale

Kingspan Environmental reserve the right to alter the details of this drawing without prior notice. This drawing is copyright and may not be reproduced or used without the written permission of Kingspan Environmental.

