

Notes:

1. This drawing is for 'Dimensional Information Only'. It is essential that this drawing is read in conjunction with the 'Installation Guidelines' supplied with the unit.
2. BioDisc Tank & Cover & Reed Bed Tray are manufactured from glass reinforced plastic (GRP) Cover is finished in Greento BS4800 Tint 18.B.25
3. For desludging procedure see Maintenance Handbook.
4. Electrical Supply - 240Volts, 2 Amps, Single Phase, Control Panel Supplied.
5. BioDisc must only be lifted by 3no. lugs provided.
6. Reed Bed Tray must be lifted using suitable slings - Do not use chains.
7. 3no. BioDisc Inlet Inverts available - 450mm, 750mm, 1250mm
8. For Installation, Maintenance & Desludging details refer to manuals 013103 (GL0010P) & 015098 (GL0011P) for BioDisc and GL0026P for Reed Bed Tray.
9. Fill Reed Bed chamber to the top with stone and place a layer of Geotextile Membrane Cloth over the top of the stone before backfilling to ground level.
10. 85mm fall across BioDisc from Inlet to Outlet.
11. Cable Duct hole diameter in case suit conduit to be used.

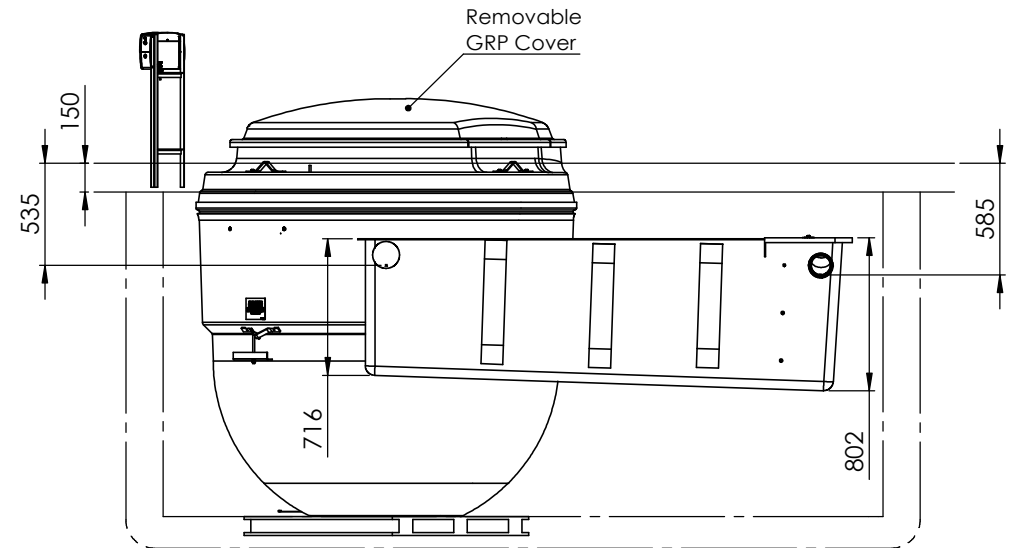
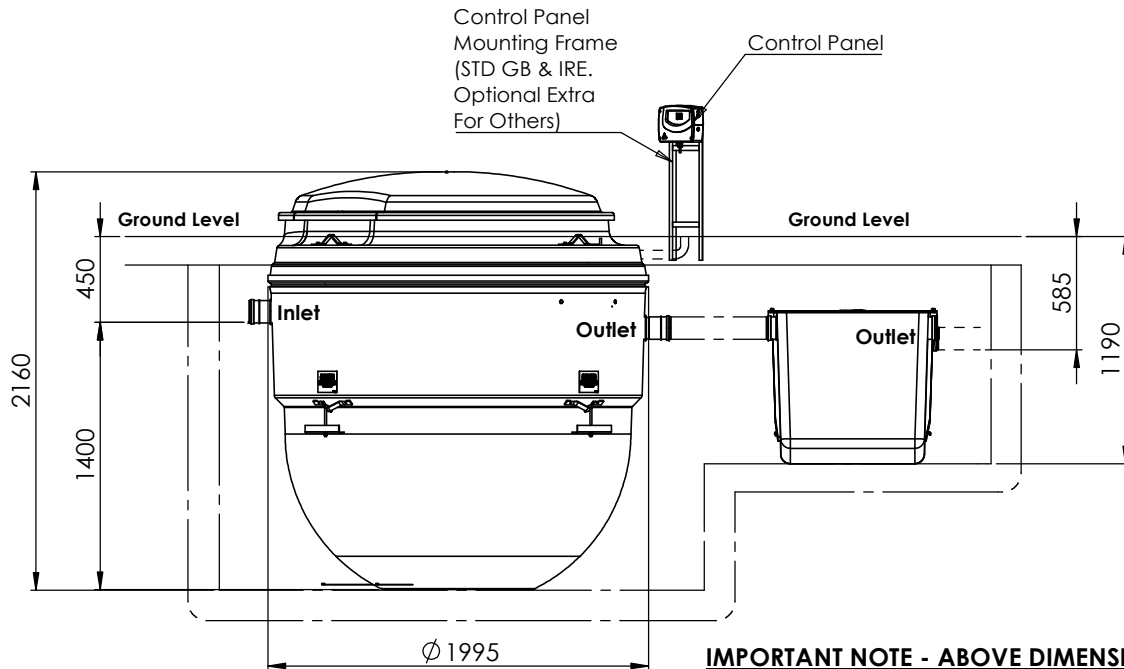

IMPORTANT NOTE - ABOVE DIMENSIONS SUIT 450mm BIODISC INLET INVERT.

Please check with Kingspan Environmental that this drawing is the latest issue

Issue	Date	Drawn by	Approved by
03	13.05.16	JMcM	
02	20.08.15	T.Kelly	

Description
Percolation Detail Added to Page 2
CC1259 - Control Panel Mounting Frame Options Updated

Material : Various	Tolerance :
Finish :	Thickness : n/a
Weight : 656.64 Kg Kgs	Surface Area :

Drawing : DS1266P	
BA-BB BioDisc + Reed Bed Sales Drawing	

All dimensions in mm

Scale: Not to scale

Kingspan Environmental reserve the right to alter the details of this drawing without prior notice. This drawing is copyright and may not be reproduced or used without the written permission of Kingspan Environmental.



Notes:

EPA PERCOLATION AREA FOLLOWING TERTIARY TREATMENT

AREA = 'T' (VALUE) x 0.125 X PE

EXAMPLE:

AREA = 'T' 41 x 0.125 x 6 = 30.75m²

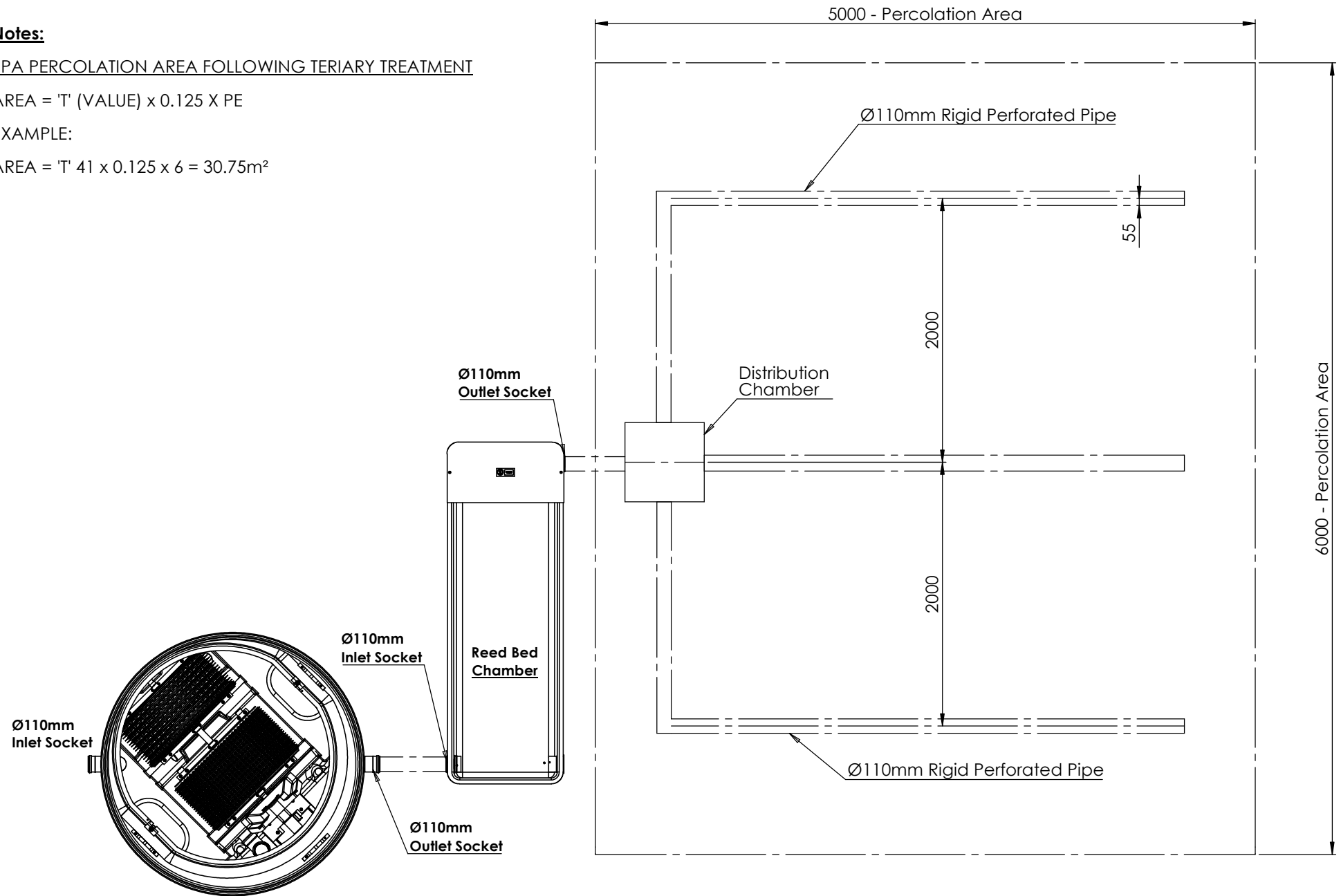

**BioDisc
Treatment Plant**

Material : Various	Tolerance :
Finish :	Thickness : n/a
Weight : 656.64 Kg Kgs	Surface Area :

Drawing : DS1266P	Page 2 of 3
BA-BB BioDisc + Reed Bed Sales Drawing	

All dimensions in mm

Scale: Not to scale

Kingspan Environmental reserve the right to alter the details of this drawing without prior notice. This drawing is copyright and may not be reproduced or used without the written permission of Kingspan Environmental.



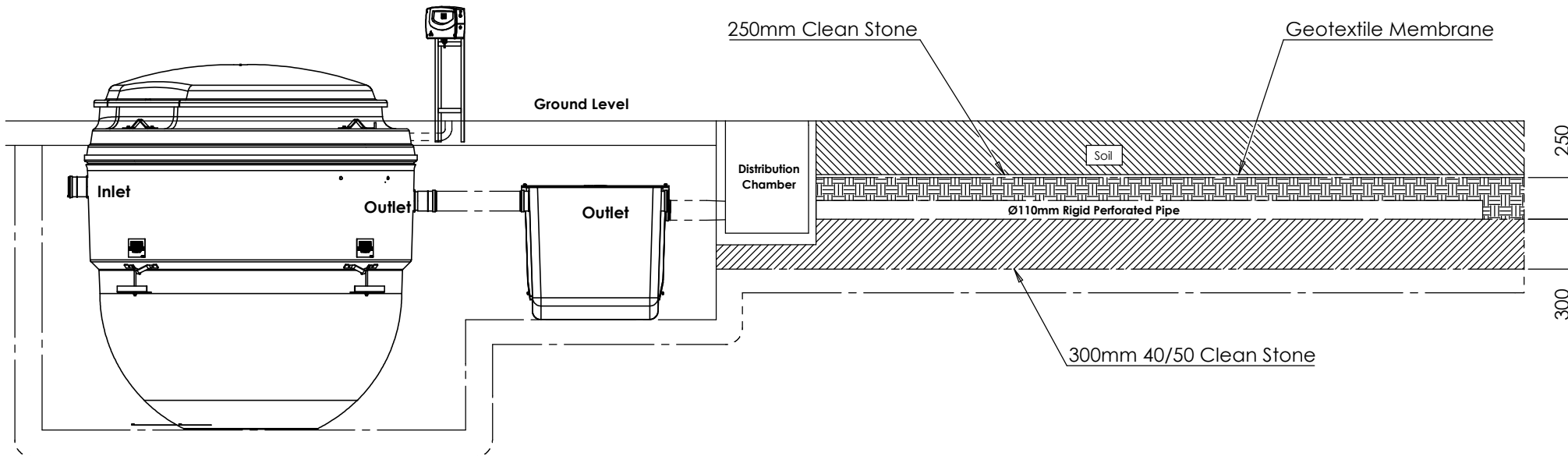

Material : Various	Tolerance :
Finish :	Thickness : n/a
Weight : 656.64 Kg Kgs	Surface Area :

Drawing : DS1266P	Page 3 of 3
BA-BB BioDisc + Reed Bed Sales Drawing	

All dimensions in mm

Scale: Not to scale

Kingspan Environmental reserve the right to alter the details of this drawing without prior notice. This drawing is copyright and may not be reproduced or used without the written permission of Kingspan Environmental.

